

7.0x5.0 SMD Crystal

FEATURE

- Rugged AT-cut crystal construction.
- Extremely compact SMD package.
- High precision characteristic covering up to high frequency range.
- Automatic mounting.
- Embossed taping specification.
- Reflow soldering.
- Pb-free and RoHS/Green compliant.

APPLICATIONS

- Ideally suited designed for disc drives, PCMCIA, PCs and hand-held electronic products.

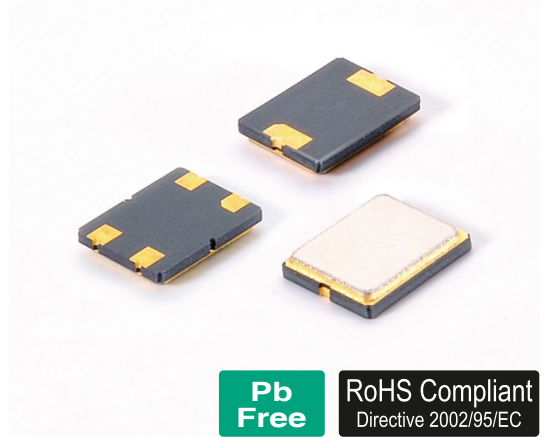

Pb Free

RoHS Compliant
Directive 2002/95/EC

Electrical Specifications 电气参数

型号	Holder Type	7.0x5.0mm Ceramic Surface Mount
频率范围	Frequency Range	6.000 to 150.000 MHz
调整频差	Frequency Tolerance (ΔF) (at 25°C)	± 10 ppm to ± 30 ppm
温度频差	Frequency Drift	± 10 ppm to ± 30 ppm ※(See Notes)
工作温度范围	Operating Temperature Range	-20°C - +70°C / -40°C - +85°C
储存温度范围	Storage Temperature Range	-40°C - +85°C / -55°C - +125°C
老化	Aging (25°C)	± 3 ppm/ year max.
静电容	Shunt Capacitance (C0)	7pF max.
激励功率	Drive Level	100 μ W (300 μ W max.)
绝缘阻抗	Insulation Resistance (Rs)	500 Megaohms Minimum at D.C.100V
负载电容	Load Capacitance (CL)	Suggested by customer

※Notes: ± 10 , ± 20 , ± 30 ppm (-20°C to +70°C)
 ± 20 , ± 30 , ± 50 ppm (-40°C to +85°C) or depends on customer

Equivalent Series Resistance and Mode of Operation 等效阻抗和振荡模式

Frequency Range 频率范围	ESR (Ω) 等效阻抗	Mode 振荡模式
6.000MHz \leq f < 8.000 MHz	100 Max	基频 Fundamental
8.000MHz \leq f < 10.000MHz	60 Max	Fundamental
10.000MHz \leq f < 14.000MHz	50 Max	Fundamental
14.000MHz \leq f < 20.000MHz	40 Max	Fundamental
20.000MHz \leq f < 40.000MHz	30 Max	Fundamental
35.000MHz to 150.000MHz	80 Max	三次泛音 Third Overtone

Reflow Condition(回流焊条件)

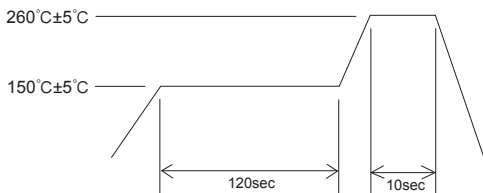

CYCLE TIME: 200sec Max.

Mechanical Dimensions 外型尺寸

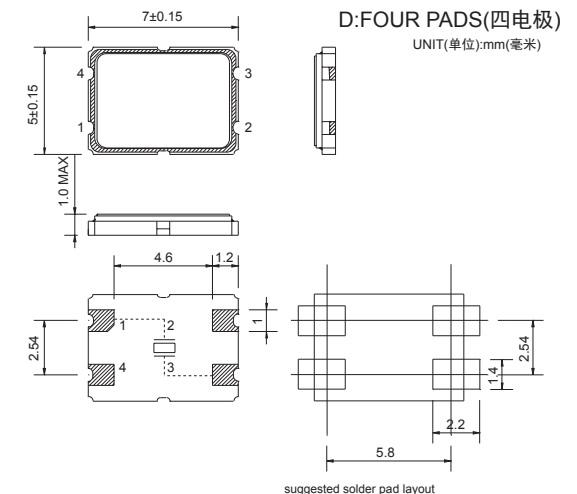
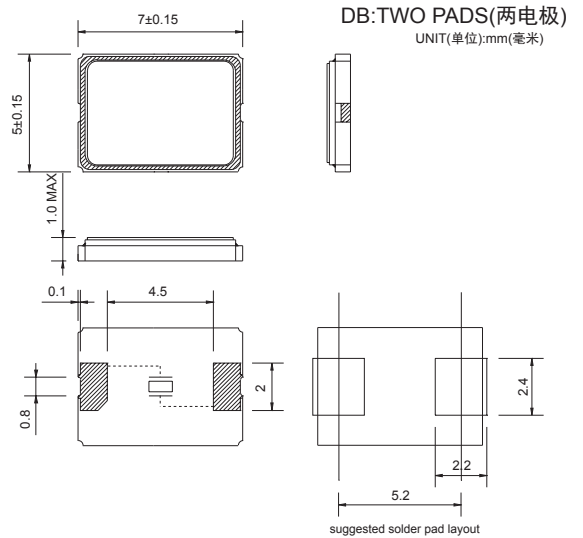

Note: #2, #4 is connected with a cover
(Please connect with GND or floating.)

地址: 深圳市宝安区航城街道三围工业路17号3栋402

Address: Room 402, Building 3, No. 17, Sanwei Industrial Road, Hangcheng Street, Bao'an District, Shenzhen

电话: 0755-29553083

网址: www.szcfelec.com

Tel.: 0755-29553083

Web: www.szcfelec.com