

5.0x3.2 SMD Crystal Oscillator

FEATURE

- Tight frequency tolerance.
- Pin-compatible with standard 5.0x3.2mm packages.
- Low power standby mode.
- surface mounting and automatically loaded.
- Reflow solder is possible.
- Lower noise and current with reduced power consumption.
- Built-in C-MOS IC with tri-state function.
- Pb-free and RoHS/Green compliant.

APPLICATIONS

- Ideally suited designed for use in Ethernet, fiber channel, PCs, NB, PCMCIA Cards, Palmtop Computer, Portable Applications.

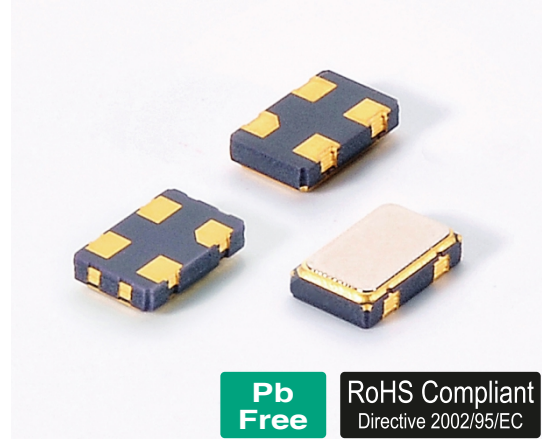

•Electrical Specifications 电气参数

型号	Holder Type	5.0x3.2mm SMD OSCILLATOR	
频率范围	Frequency Range	1.000 Mhz to 125.000 MHz	
总频差	Frequency Stability	±20ppm to ±50ppm	
输入电压	Supply Voltage	5.0V or 3.3V ±10%※(See Notes)	
工作温度范围	Operating Temperature Range	-20°C - +70°C / -40°C - +85°C	
储存温度范围	Storage Temperature Range	-40°C - +85°C/-55°C - +125°C	
占空比	Symmetry (Duty Cycle)	40/60 Standard	
输出	Output Load	10 TTL or 15pF Hmos	
消耗电流	Current Consumption (15pf only)	1.000Mhz - 35.999Mhz=25mA max	
		(5.0V)	36.000Mhz - 69.999Mhz=60mA max
		70.000Mhz - 100.000Mhz=80mA max	
	Current Consumption (15pf only)	1.000Mhz - 35.999Mhz=20mA max	
		(1.8V 2.5V 2.85V 3.3V)	36.000Mhz - 69.999Mhz=40mA max
		70.000Mhz - 125.000Mhz=60mA max	
上升/下降时间	Rise/Fall Time	5 nS max	

※Notes:The supply voltage 1.8V,2.5V,2.85V also can be made by customer.

•Mechanical Dimensions 外型尺寸

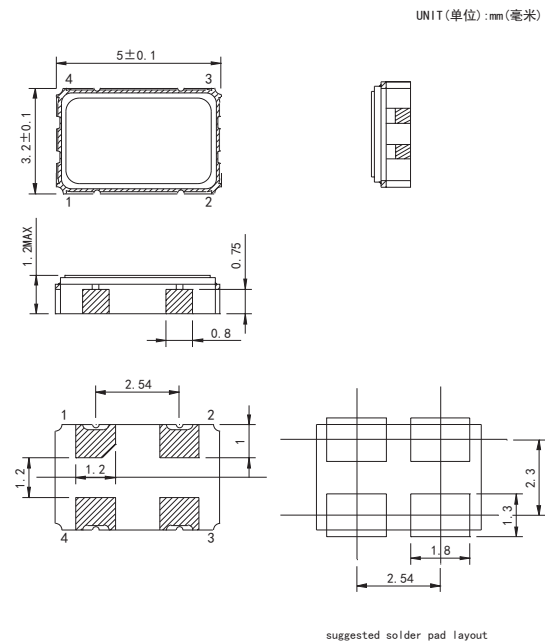

•Test Circuit (测试电路)

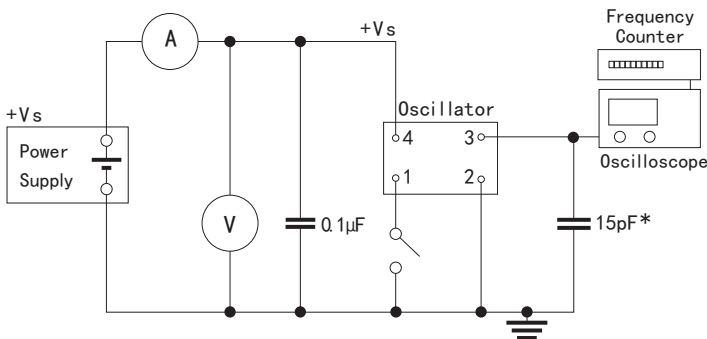

PIN	FUNCTION
1	Tri-state※(See Notes)
2	Ground
3	Output
4	Vdd

※Notes:

Tri-state: PIN 1 connected to Vdd or floating, the product is working properly;connected to GND, stops working.