

3.2x2.5 SMD Crystal Oscillator

FEATURE

- Tight frequency tolerance.
- CMOS compatible logic levels.
- Pin-compatible with standard 3.2x2.5mm packages.
- Designed for standard reflow and washing techniques.
- Low power standby mode.
- Available on tape & reel, 1000pcs per reel.
- Pb-free and RoHS/Green compliant.

APPLICATIONS

- Ideally suited designed for use in Ethernet, network adapter cards, hard disk devices, blue tooth, PCMCIA Cards, Palmtop Computer, Portable Applications.

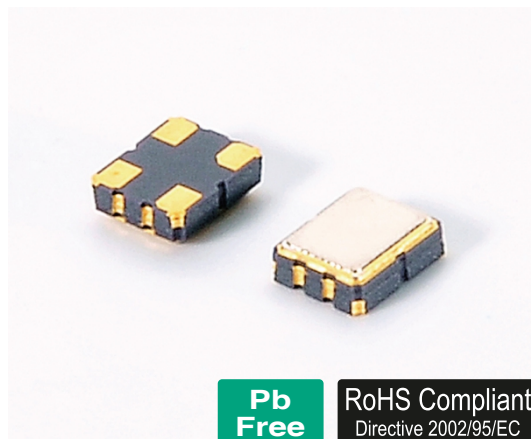

Electrical Specifications 电气参数

型号	Holder Type	3.2x2.5mm SMD OSCILLATOR
频率范围	Frequency Range	1.000 Mhz to 125.000 MHz
总频差	Frequency Stability	±20ppm to ±50ppm
输入电压	Supply Voltage	5.0V or 3.3V ±10%※(See Notes)
工作温度范围	Operating Temperature Range	-20°C - +70°C / -40°C - +85°C
储存温度范围	Storage Temperature Range	-40°C - +85°C/-55°C - +125°C
占空比	Symmetry (Duty Cycle)	40/60 Standard
输出	Output Load	15pF Hcmos or 10 TTL
消耗电流	Current Consumption (15pf only)	1.000Mhz - 49.999Mhz=25mA max
	(5.0V)	50.000Mhz - 125.000Mhz=80mA max
	Current Consumption (15pf only)	1.000Mhz - 49.999Mhz=20mA max
	(1.8V 2.5V 2.85V 3.3V)	50.000Mhz - 125.000Mhz=60mA max
上升/下降时间	Rise/Fall Time	5 nS max

※Notes: The supply voltage 1.8V, 2.5V, 2.85V also can be made by customer.

Mechanical Dimensions 外型尺寸

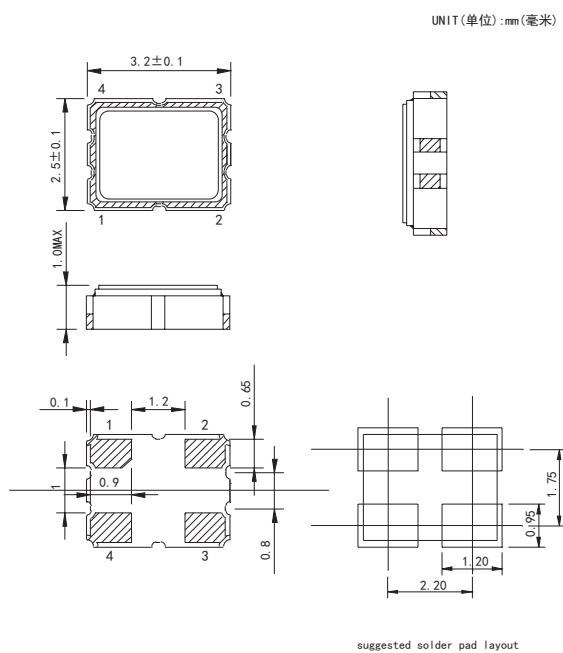

Test Circuit (测试电路)

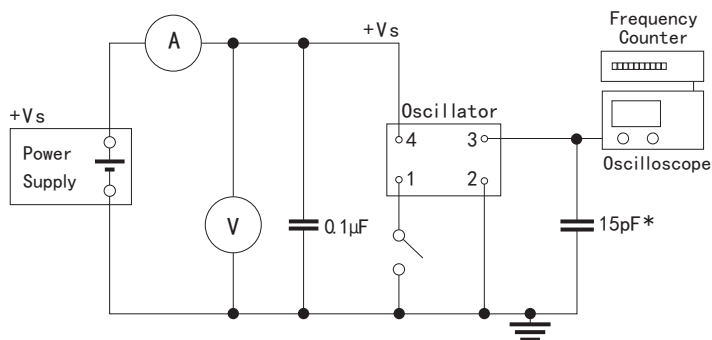

PIN	FUNCTION
1	Tri-state※(See Notes)
2	Ground
3	Output
4	Vdd

※Notes:

Tri-state: PIN 1 connected to Vdd or floating, the product is working properly; connected to GND, stops working.

地址: 深圳市宝安区航城街道三围工业路17号3栋402

Address: Room 402, Building 3, No. 17, Sanwei Industrial Road, Hangcheng Street, Bao'an District, Shenzhen

电话: 0755-29553083

网址: www.szcfelec.com

Tel.: 0755-29553083

Web: www.szcfelec.com